



Product Summary

$V_{(BR)DSS}$	$R_{DS(on)TYP}$	I_D
60V	2.8m Ω @10V	140A
	4.5m Ω @4.5V	

Feature

- Split Gate Trench Technology
- Low $R_{DS(ON)}$
- Low Gate Charge
- Low Gate Resistance
- 100% UIS Tested

Application

- Power Management
- Load Switching
- Motor Driving
- High frequency switching, synchronous rectification

TO-252-2L

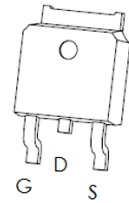

Schematic diagram

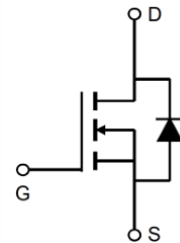

Package Marking and Ordering Information

Part Number	Package	Marking	Packing	Reel Size	Tape Width	Qty
GPT030N06LTF	TO-252-2L	T030N06L	Reel & Tape	330mm	16mm	2500pcs

ABSOLUTE MAXIMUM RATINGS ($T_A = 25^\circ\text{C}$ unless otherwise noted)

Parameter	Symbol	Value	Unit
Drain-Source Voltage	V_{DS}	60	V
Gate-Source Voltage	V_{GS}	± 20	V
Continuous Drain Current ¹	I_D	$T_C = 25^\circ\text{C}$	140
		$T_C = 100^\circ\text{C}$	88
Pulsed Drain Current ²	I_{DM}	440	A
Single Pulsed Avalanche Current ³	I_{AS}	42	A
Single Pulsed Avalanche Energy ³	E_{AS}	441	mJ
Power Dissipation ⁵	P_D	78	W
Thermal Resistance from Junction to Ambient ⁶	$R_{\theta JA}$	40	$^\circ\text{C/W}$
Thermal Resistance from Junction to Case	$R_{\theta JC}$	1.6	$^\circ\text{C/W}$
Junction Temperature	T_J	150	$^\circ\text{C}$
Storage Temperature	T_{STG}	-55~ +150	$^\circ\text{C}$

MOSFET ELECTRICAL CHARACTERISTICS (T_A = 25°C unless otherwise noted)

Parameter	Symbol	Test Condition	Min	Type	Max	Unit
Off Characteristics						
Drain-Source Breakdown Voltage	V _{(BR)DSS}	V _{GS} = 0V, I _D = 250μA	60			V
Zero Gate Voltage Drain Current	I _{DSS}	V _{DS} = 60V, V _{GS} = 0V			1	μA
Gate-Body Leakage Current	I _{GSS}	V _{GS} = ±20V, V _{DS} = 0V			±100	nA
On Characteristics⁴						
Gate Threshold Voltage	V _{GS(th)}	V _{DS} = V _{GS} , I _D = 250μA	1.2	1.8	2.5	V
Drain-Source On-Resistance	R _{DS(on)}	V _{GS} = 10V, I _D = 20A		2.8	3.5	mΩ
		V _{GS} = 4.5V, I _D = 15A		4.5	6.5	mΩ
Forward Transconductance	g _{FS}	V _{DS} = 5V, I _D = 20A	50			S
Dynamic Characteristics						
Input Capacitance	C _{iss}	V _{DS} = 30V, V _{GS} = 0V, f = 1MHz		3328		pF
Output Capacitance	C _{oss}			1143		
Reverse Transfer Capacitance	C _{rss}			25		
Gate Resistance	R _g	V _{DS} = 0V, V _{GS} = 0V, f = 1MHz		0.8		Ω
Switching Characteristics						
Total Gate Charge	Q _g	V _{DS} = 30V, V _{GS} = 10V, I _D = 30A		52		nC
Gate-Source Charge	Q _{gs}			10		
Gate-Drain Charge	Q _{gd}			9.3		
Gate Plateau Voltage	V _{plateau}			3.3		V
Turn-On Delay Time	t _{d(on)}	V _{DD} = 30V, V _{GS} = 10V, I _D = 20A, R _G = 3Ω		4		ns
Turn-On Rise Time	t _r			5		
Turn-Off Delay Time	t _{d(off)}			30		
Turn-Off Fall Time	t _f			15		
Source-Drain Diode Characteristics						
Diode Forward Voltage ⁴	V _{SD}	V _{GS} = 0V, I _S = 20A			1.2	V
Diode Continuous Forward Current ¹	I _S	T _C = 25°C			110	A
Diode Pulse Forward Current ²	I _{SM}	T _C = 25°C			440	A
Diode Reverse Recovery Time	t _{rr}	I _F = 20A, dI/dt = 100A/μs		38		ns
Diode Reverse Recovery Charge	Q _{rr}	I _F = 20A, dI/dt = 100A/μs		35		nC

Notes:

- 1.The maximum current rating is limited by package. And device mounted on a large heatsink.
- 2.Pulse Test: Pulse Width ≤ 10μs, duty cycle ≤ 1%.
- 3.EAS condition: V_{DD} = 30V, V_{GS} = 10V, L = 0.5mH, R_G = 25Ω Starting T_J = 25°C.
- 4.Pulse Test: Pulse Width ≤ 300μs, duty cycle ≤ 2%.
- 5.The power dissipation P_D is limited by T_{J(MAX)} = 150°C. And device mounted on a large heatsink.
- 6.Device mounted on 1in² FR-4 board with 2oz. Copper, in a still air environment with T_A = 25°C.

Typical Characteristics

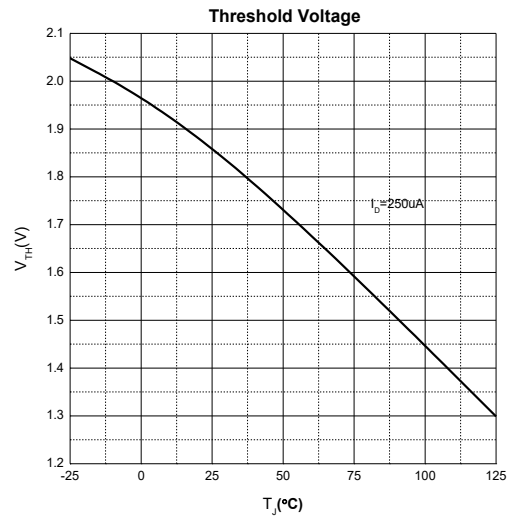
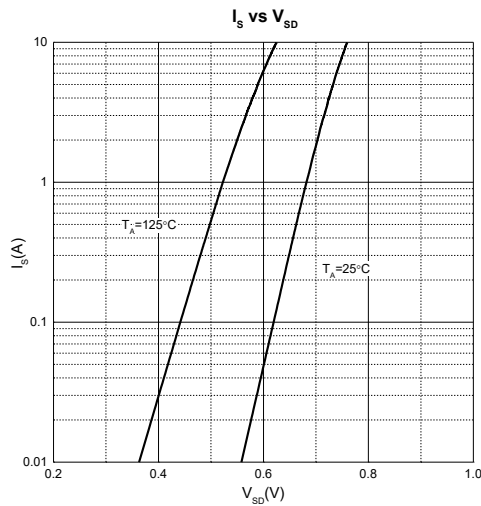
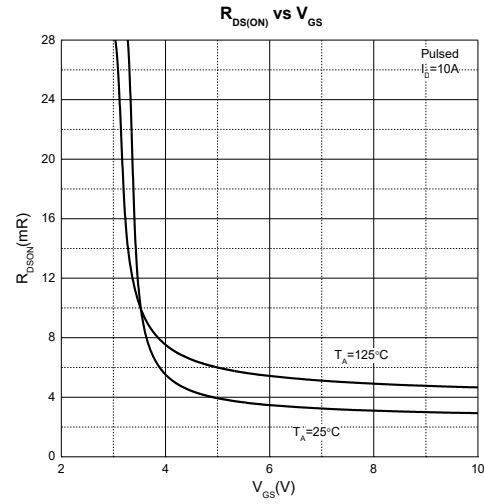
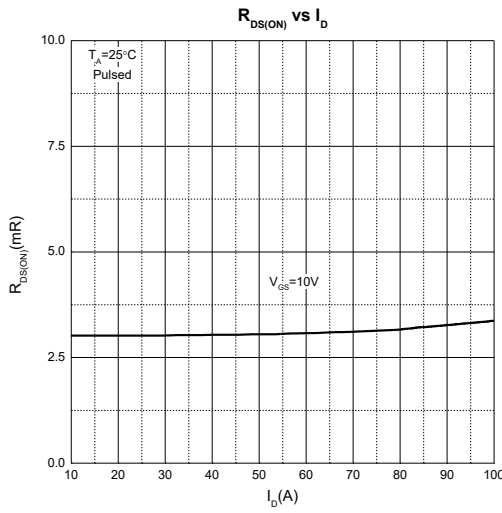
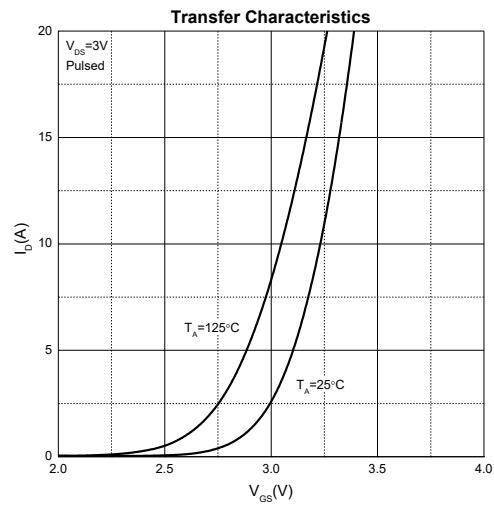

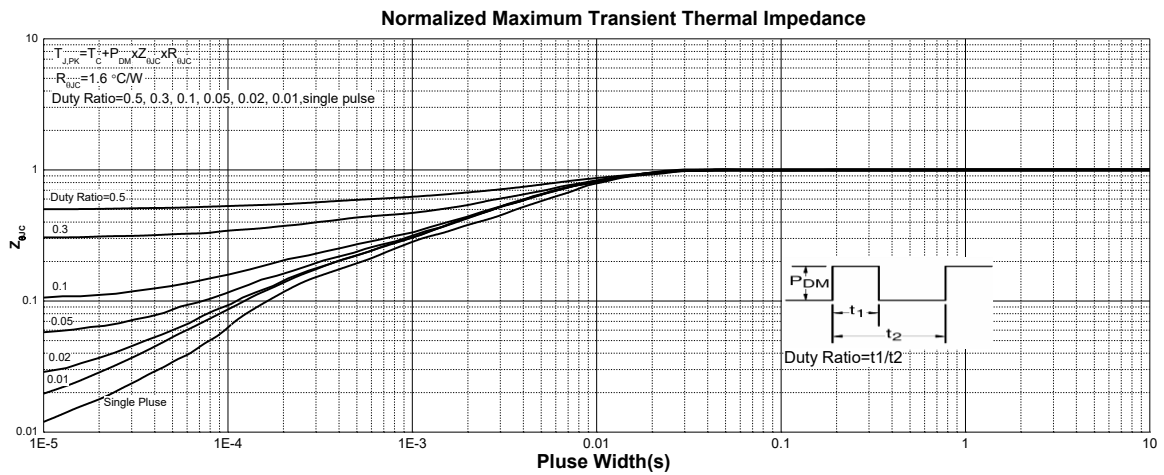
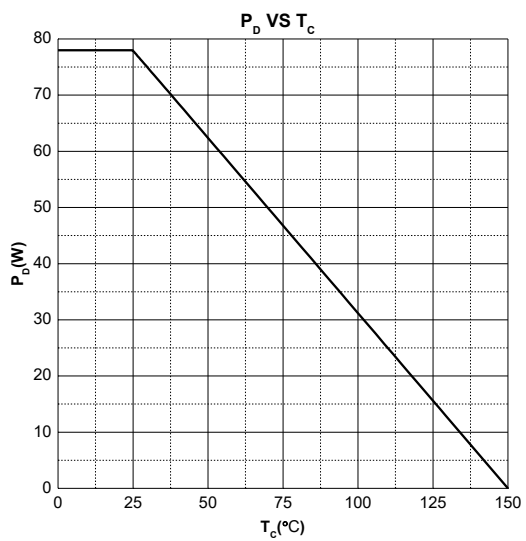
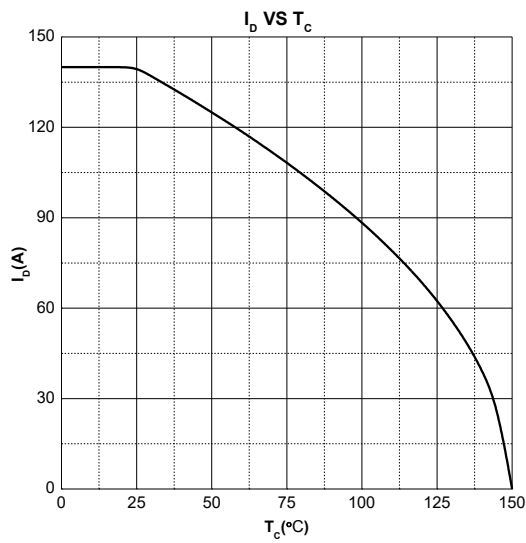
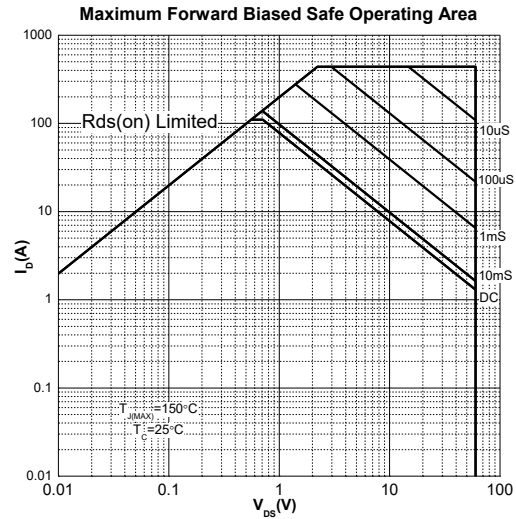
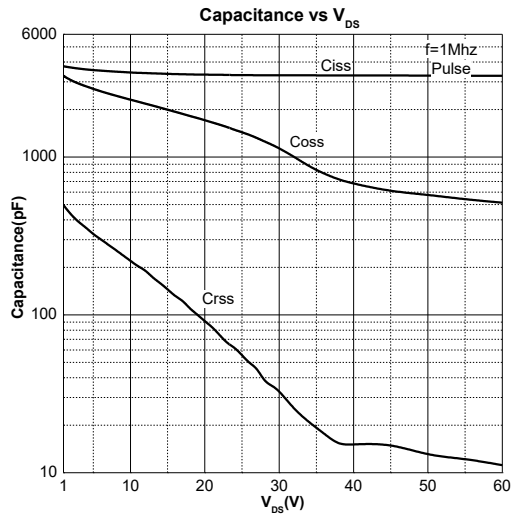

Test Circuit

Gate Charge Test Circuit & Waveform

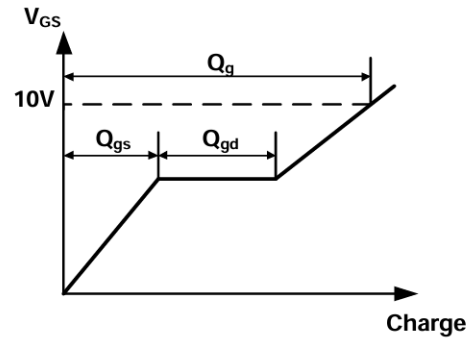
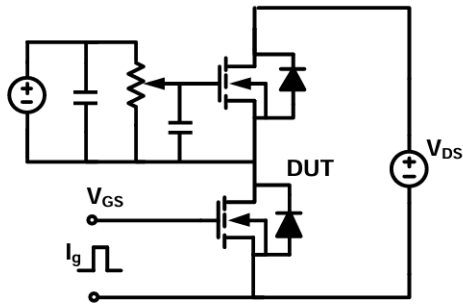

Resistive Switching Test Circuit & Waveform

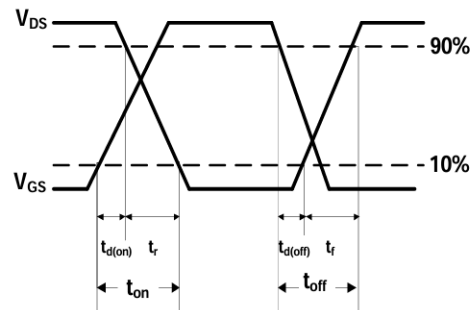
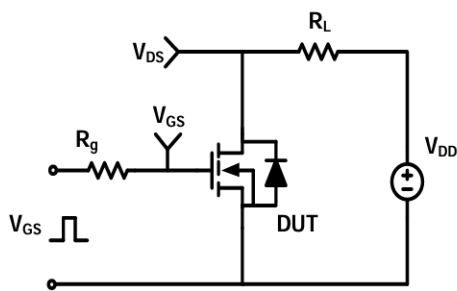

Unclamped Inductive Switching (UIS) Test Circuit & Waveform

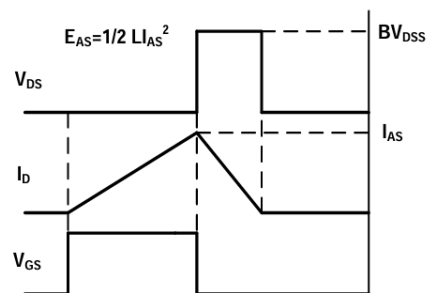
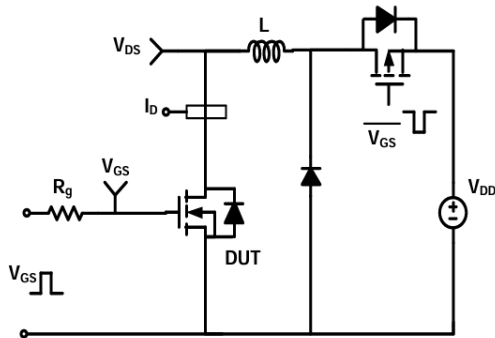

Diode Recovery Test Circuit & Waveform

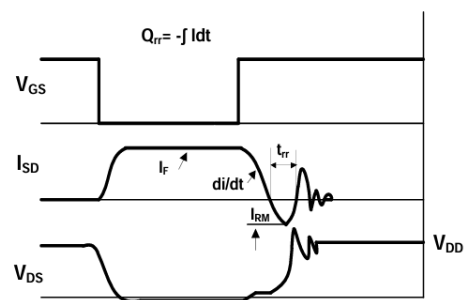
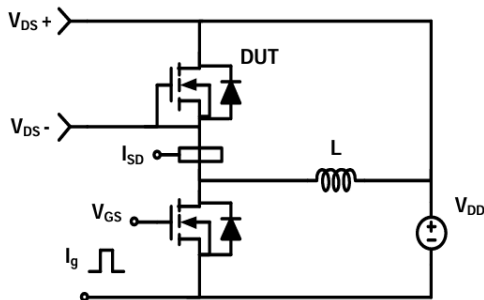

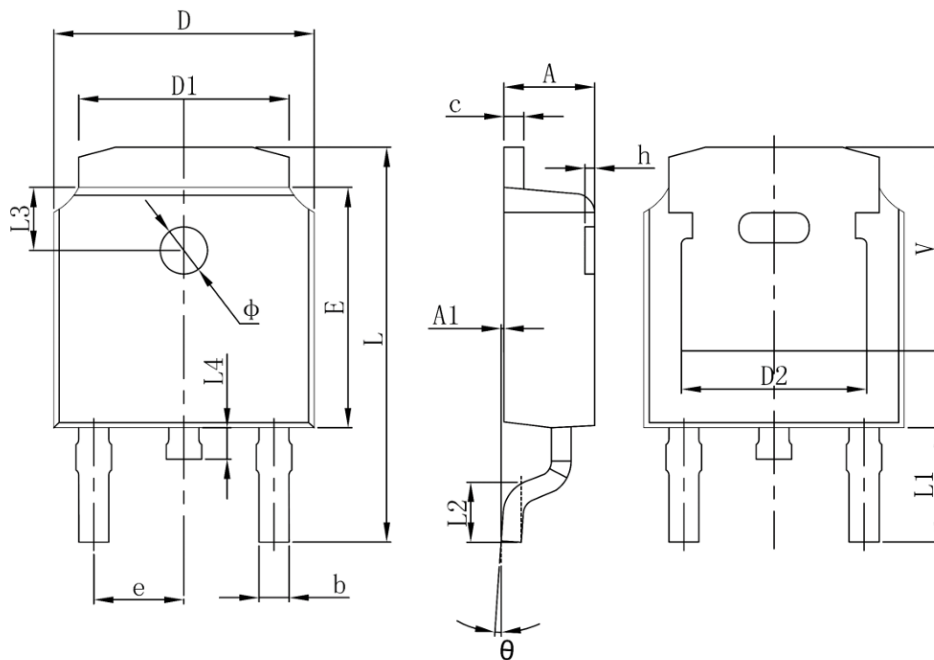
TO-252-2L Package Information

Symbol	Dimensions In Millimeters		Dimensions In Inches	
	Min.	Max.	Min.	Max.
A	2.200	2.400	0.087	0.094
A1	0.000	0.127	0.000	0.005
b	0.635	0.860	0.025	0.034
c	0.460	0.580	0.018	0.023
D	6.500	6.700	0.256	0.264
D1	5.100	5.460	0.201	0.215
D2	4.830REF		0.190REF	
E	6.000	6.300	0.236	0.248
e	2.186	2.386	0.086	0.094
L	9.712	10.312	0.382	0.406
L1	2.900REF		0.114REF	
L2	1.400	1.700	0.055	0.067
L3	1.600REF		0.063REF	
L4	0.600	1.000	0.024	0.039
phi	1.100	1.300	0.043	0.051
theta	0°	8°	0°	8°
h	0.000	0.300	0.000	0.012
V	5.250REF		0.207REF	

Attention:

- GreenPower Electronics reserves the right to improve product design function and reliability without notice.
- Any and all semiconductor products have certain probability to fail or malfunction, which may result in personal injury, death or property damage. Customer are solely responsible for providing adequate safe measures when design their systems.
- GreenPower Electronics products belong to consumer electronics or other civilian electronic products.